

Jefa linear autopilot drive product sheet

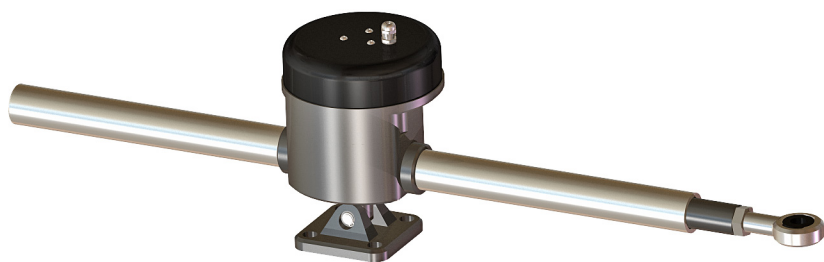

The Danish company Jefa Steering has added another top product in it's range: The autopilot linear drive LD2. Jefa produces many bigger autopilot drives, but a linear drive for boats up to 37 foot was missing. The linear drive LD2 has to be combined with autopilot electronics to make up a complete autopilot system. The drive is compatible with all major autopilot course computers.

The linear drive LD2 has a unique drive system: The electric motor is a flat wound (pancake) motor which is unique for this application as it is specially made for constant speeding up and slowing down. The reduction is achieved by a double planetary gearbox which drives the four drive gears for the gear spindle. This special electric motor and drive system make the linear drive very strong and economic in power consumption.

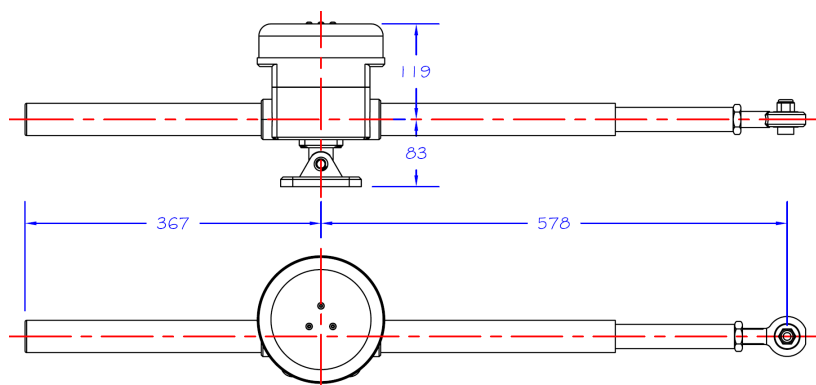
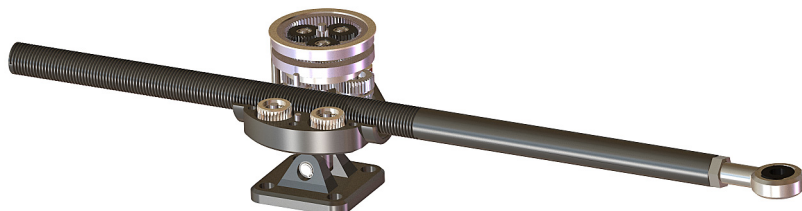

This drawing shows the main dimensions of the linear drive in the midships position (half extended). The gear spindle is protected at both sides by a protection tube and sealed off at the end so no dirt can enter the drive and gears.

The linear drive is designed to drive the rudder with a maximum rudder angle of 36° on 250 mm (10") pin centres. When the rudder angle exceeds 36°, different pin centres have to be used. It's very important that proper rudder stops are fitted (green in the right drawing) so the drive isn't used as travel limiter as this will cause mechanical damage. The maximum rated thrust of the drive is 400 Kgf resulting in a maximum rudder torque of 100 KgM. (this is the same torque as when you push with 100 Kg on the end of a 1 meter long tiller).

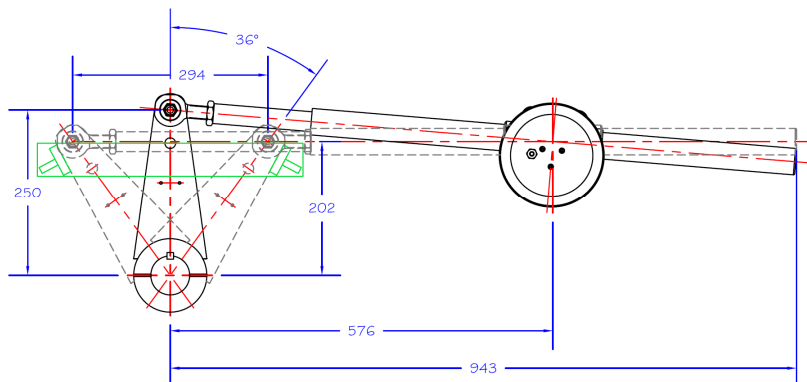

Overview of features:

- Rated rudder torque 100 KgM (linear thrust of 400 Kgf). Maximum boat length 37 foot.
- Maximum power consumption 10 Amp. at 12 Volts. Average power consumption 1-2 amps.
- Engagement clutch with very low power consumption (0.75 Amps. at 12 Volts).
- Extremely light to back-drive, so no loss of feel in tiller or steering system.
- Good hard over speed of 8.5 seconds (no load), and very low speed loss under load.
- Most parts are made from anodised Aluminium 6082 resulting in a light and strong solution.

Jefa Steering ApS
Agenavej 43
2670 Greve
Denmark
www.jefa.com
sales@jefa.com

